

# Universal 3 Phase Voltage Monitor DLMU Series (SPDT & N.O. or N.C.) Motor Protector



ANSI Device #27/47/59



- Protects Against: Phase Loss, Phase Reversal, Over, Under and Unbalanced Voltages, Over/Under Frequency
- 35 mm DIN Rail or Surface Mounting
- SPDT Isolated 10A Relay Contact
- N.O. or N.C. SPST Isolated 2A Relay Contact
- LED Indicates: Relay, Faults, & Time Delays
- Universal Line Voltage 240 ... 480 V AC in One Unit
- 600 V AC Version Available
- 3 Wire Connection for Delta or Wye Systems
- ASME A17.1 rule 210.6
- NEMA MG1 14:30, 14:35
- IEEE C62.41-1991 Level B

Approvals:

### Accessories

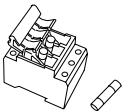

3-phase fuse block/disconnector  
P/N: FH3P  
2 Amp Fuse  
P/N: P0600-11

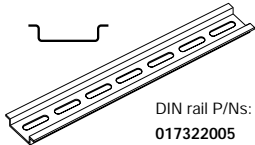

DIN rail P/Ns:  
017322005

See accessory pages for specifications.

### Description

Preliminary Data Sheet - Available 1st Quarter 2008

The DLMU Series is a universal voltage, 3 Phase Voltage Monitor. It continuously measures the voltage of each of the three phases with microcontroller accuracy and compares the value to preset trip points. It separately senses Phase Reversal, Over, Under and Unbalanced voltages including Phase Loss and over or under frequency. Protection is assured during periods of large average voltage fluctuations, or when regenerated voltages are present. The unit trips within 200 ms when phase loss is detected. Adjustable time delays are included to prevent nuisance tripping and short cycling of sensitive equipment. The 10A isolated SPDT and 2A alarm output relay contacts trip when a phase voltage exceeds the trip limits for the trip delay. Nominal line voltage, voltage unbalance, and time delays are knob adjustable. The phase loss set point and the acceptable frequency range are fixed. Both Delta and Wye systems can be monitored; no connection to neutral is required.

### Operation

Upon application of line voltage, the output is de-energized and the restart delay begins. If all the three phase voltages are within the acceptable range, the output energizes at the end of the restart delay. The microcontroller circuitry automatically senses the voltage range, and selects the correct operating frequency (50 or 60hz). The over and under voltage trip points are set automatically. When the measured value of any phase voltage exceeds the acceptable range limits (lower or upper) the trip delay begins. At the end of the trip delay the output relay de-energizes. If the phase voltage returns to an acceptable value before the trip delay expires, the trip delay is reset and the output remains energized. Under, over, and unbalanced voltages plus over or under frequency must be sensed for the complete trip delay before the unit trips. The unit trips in 200 ms when phase loss or reversal are sensed. The unit will not energize if a fault is sensed as the line voltage is applied.

**Reset:** Reset is automatic upon correction of the voltage or frequency fault or phase sequence.

### Connection

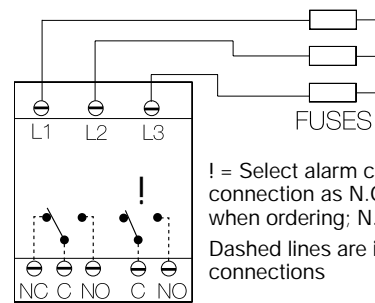

L1, L2, L3 = Line Voltage Input  
NO = Normally Open Contact  
NC = Normally Closed Contact  
C = Common, Transfer Contact

**CAUTION:** 2 amp max. fast acting fuses are recommended to protect the equipment's wiring. They are not required to protect the DLMU.

### Restart Delay Options:

**L= Lockout or minimum OFF time.** The restart delay begins when the output trips. The unit cannot be re-energized until the restart delay is complete. This provides a minimum off time or lockout time to allow equipment sensitive to short cycling, time to reset. If the fault is corrected after the restart delay is complete the output energizes immediately. The restart delay also occurs when line voltage is applied/reapplied.

**R= Restart Delay on fault correction.** The restart delay begins when line voltage is reapplied or when a voltage fault is corrected. This option is normally selected when staggered restarting of multiple motors on a power system is required.

**N= No Restart Delay.** 0.6 second initialization delay on application of line voltage applies.

### Restart Notes:

All restart options remain reset when the following conditions are detected:

- 1.) Phase Loss (phase unbalance greater than 25%)
- 2.) Average Line Voltage less than 120VAC
- 3.) Phase Reversal

The restart delay begins when the condition is corrected.

### LED Operation

The LED flashes green during the restart delay, then glows green when the output energizes. It flashes red during the trip delay then glows red when the output de-energizes. It flashes red/green if phase reversal is sensed. If a fault is sensed during the restart delay, the LED will glow red during that portion or the full restart delay.

### LED Flashing Table

Trip Delay	Red	ON/OFF	120 FPM
Restart Delay	Green	ON/OFF	60 FPM
Phase Reversal	Red/Green	Alternate	120 FPM

FPM = Flashes per minute

### Ordering Table

DLM Series	X Line Voltage	X Output	X Restart Function	X Voltage Unbalance	X Trip Delay	X Restart Delay
	-U - 200... 480 V AC -H - 500... 600 V AC	-B - SPDT & N.O. -C - SPDT & N.C.	-L - Lockout, Min Off Time -R - Staggered Restarting -N - No Restart Delay	-A - Adjustable 2 ... 10% Fixed: Specify Unbalance 2...10% in 1% increments using two digits [ 04 ]	-A - Adjustable 1...30s Fixed: Specify delay 1... 30 s in 1 s increments, using two digits [ 20 ]	-A - Adjustable* 0.6 ...300 s -N - No Restart Delay

### Example P/N:

- DLMUBLAAA** = 200 ... 480 V, SPDT & N.O., Lockout Function Delay, Adjustable Unbalance, Trip and Restart Delay
- DLMUBRAAA** = 200 ... 480 V, SPDT & N.O., Restart Delay on fault correction, Adjustable Unbalance, Trip and Restart Delay
- DLMUCNAAN** = 200 ... 480 V, SPDT & N.C., No Restart Delay, Adjustable Unbalance and Trip Delay
- DLMUCL0420A** = 200 ... 480 V, SPDT & N.C., Lockout Function, 4% Unbalance, 20 s Trip Delay, Adjustable Restart Delay

**Note:** \* Selection "A" is only available for L or R restart functions

# Universal 3 Phase Voltage Monitor DLMU Series (SPDT & N.O. or N.C.) Motor Protector

Voltage  
Monitors

## Technical Data

<b>Line Voltage</b>		3 phase Delta or Wye with no connection to neutral
Type		
Operating Voltage	200 ... 480 V AC	
	600 V AC	
Line Frequency	50 or 60 Hz Automatically detected	
<b>Phase Loss</b>		≥ 25% Unbalance
	Response Time	≤ 200ms
<b>Undervoltage and Voltage Unbalance</b>		Voltage detection with delayed trip & automatic reset 109 to 113% of the adjusted line voltage ≅ -3% of the trip voltage 88 ... 92% of the adjusted line voltage ≅ +3% of the trip voltage Adjustable 2 ... 10%; or specify fixed unbalance of 2 ... 10% in 1% increments ≅ -0.7% Unbalance Over/Undervoltage, Voltage Unbalance, Over/Under Frequency Adjustable from 1 ... 30 s; or specify fixed delay 1 ... 30 s in 1 s increments ± 15% Adjustable from 0.6 ... 300 s; if no restart delay is selected a 0.6 s initialization delay applies ± 15% ±4%; Reset ±3%; 50 or 60 Hz A, B, C, L1, L2, L3 ≤ 200 ms Automatic
Type		
Overvoltage:	Trip Voltage Reset Voltage	
Undervoltage:	Trip Voltage Reset Voltage	
Voltage Unbalance:	Trip Set Point Reset on Balance	
Trip Delay	Active On Range Tolerance	
Restart Delay	Range Tolerance	
Over/Under Frequency	Trip / Reset	
Phase Sequence		
Response Time -Phase Reversal & Phase Loss		
Reset		
<b>Output</b>		
Type		
Control Contact	Form Rating	
Alarm Contact	Form Rating	
Life		
<b>Protection</b>		IEEE C62.41-1991 Level B ≥ 2500 V RMS input to output
<b>Mechanical</b>		Surface mount with 2 #8 (M4 x 0.7) screw or snap on 35mm DIN Rail Note: 0.25 in. (6.35 mm) spacing between units or other devices is required 4.33 x 2.95 x 1.97 in. (110 x 75 x 50 mm) Screw terminals with captive wire clamps for up to #14 AWG (2.5 mm <sup>2</sup> ) wire IP 20 Touch Proof with removable covers installed
Mounting		
Package Termination		
<b>Environmental</b>		-40°C ... +60°C -40°C ... +85°C 95% relative, non-condensing ≅ 8.6 oz (244 g)
Operating Temperature		
Storage Temperature		
Humidity		
Weight		

7

### Mechanical View

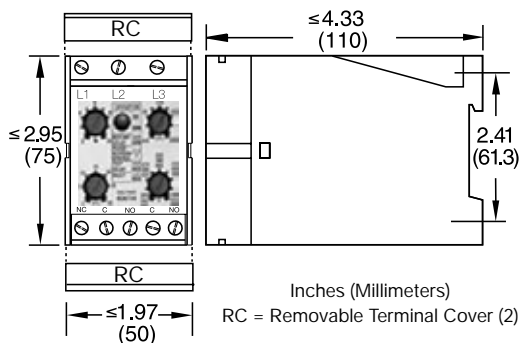

DLMU2BOP

12.11.07

# 3 Phase Voltage Monitor DLM Series Motor Protector



ANSI Device #27/47/59



- Protects Against: Phase Loss, Phase Reversal, Overvoltage, Undervoltage, and Voltage Unbalance
- 35 mm DIN Rail or Surface Mounting
- SPDT Isolated 10 A Relay Contacts
- LED Glows when All Conditions are Acceptable
- Line Voltage 110 ... 600 V AC, in 5 Ranges
- 3 Wire Connection for Delta or Wye Systems
- ASME A17.1 rule 210.6
- NEMA MG1 14:30, 14:35
- IEEE C62.41-1991 Level B

Approvals:    
Listed

## Accessories

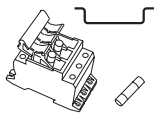

3-phase fuse block/disconnect  
P/N: P0700-241  
2 Amp Fuse  
P/N: P0600-11

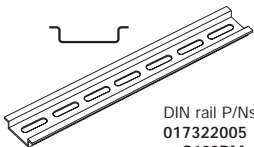

DIN rail P/Ns:  
017322005 (Steel)  
C103PM (Al)

See accessory pages for specifications.

## Description

The DLM Series continuously measures the voltage of each of the three phases. It separately senses under and over voltage, voltage unbalance including phase loss and phase reversal. Protection is assured during periods of large average voltage fluctuations, or when regenerated voltages are present. It can be mounted on 35 mm DIN rail or surface mounted with two screws. All connections are screw terminals with clamps. Connections can be covered with included removeable covers.

## Operation

The output relay is energized and the LED glows when all voltages are acceptable and the phase sequence is correct. Undervoltage, overvoltage, and voltage unbalance must be sensed for continuous trip delay period before the relay and the LED are de-energized. Re-energization is automatic upon correction of the fault condition. The output relay will not energize if a fault condition is sensed as power is applied.

## Field Adjustment:

Set voltage, trip delay, and voltage unbalance percentage (consult equipment manufacturer's specifications). Make connection to all three line phases as shown in the connection diagram. Apply power. If the relay fails to energize, check the wiring of all 3 phases, voltage, and phase sequence. If phase sequence is incorrect, swap any two wires. No further adjustment should be required to achieve maximum equipment protection.

## Connection

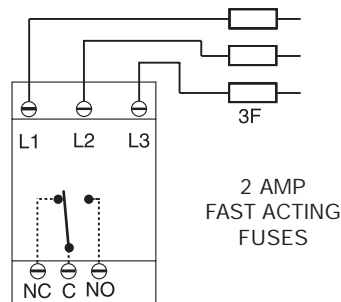

F = Fuses NO = Normally Open

NC = Normally Closed C = Common, Transfer Contact

**CAUTION:** 2 amp max fast acting fuses must be installed externally in series with each input.

## Ordering Table

Voltage	Voltage Unbalance	Trip Delay	Part Number
120 V AC	2 ... 8%	2 ... 20 s	DLM411
240 V AC	2 ... 8%	2 ... 20 s	DLM611
380 V AC	2 ... 8%	2 ... 20 s	DLM811
480 V AC	2 ... 8%	2 ... 20 s	DLM911
600 V AC	2 ... 8%	2 ... 20 s	DLM011

# 3 Phase Voltage Monitor DLM Series Motor Protector

## Technical Data

<b>Line Voltage</b>		3 phase Delta or Wye with no connection to neutral																					
Type		<b>Model</b>	<b>Line Voltage Range</b>	<b>Line Voltage Max.</b>	<b>Calibration Frequency</b>																		
Operating Voltage		120	110 ... 130 V AC	145 V AC	60 Hz																		
		240	200 ... 240 V AC	270 V AC	60 Hz																		
		380	360 ... 430 V AC	480 V AC	50 Hz																		
		480	400 ... 480 V AC	530 V AC	60 Hz																		
		600	500 ... 600 V AC	600 V AC	60 Hz																		
Line Frequency		50 ... 60 Hz																					
Phase Sequence		ABC																					
<b>Overvoltage, Undervoltage &amp; Voltage Unbalance</b>		Voltage detection with delayed trip & automatic reset																					
Type																							
Overvoltage & Undervoltage:		<table border="1" style="width: 100%; border-collapse: collapse;"> <thead> <tr> <th colspan="2">Voltage Unbalance</th> </tr> <tr> <th>Selected Unbalance %</th> <th>Reset %</th> </tr> </thead> <tbody> <tr> <td>2</td> <td>1.8</td> </tr> <tr> <td>3</td> <td>2.7</td> </tr> <tr> <td>4</td> <td>3.6</td> </tr> <tr> <td>5</td> <td>4.5</td> </tr> <tr> <td>6</td> <td>5.4</td> </tr> <tr> <td>7</td> <td>6.3</td> </tr> <tr> <td>8</td> <td>7.2</td> </tr> </tbody> </table>				Voltage Unbalance		Selected Unbalance %	Reset %	2	1.8	3	2.7	4	3.6	5	4.5	6	5.4	7	6.3	8	7.2
Voltage Unbalance																							
Selected Unbalance %	Reset %																						
2	1.8																						
3	2.7																						
4	3.6																						
5	4.5																						
6	5.4																						
7	6.3																						
8	7.2																						
Undervoltage Trip Point		<p>Note: A 60 Hz unit used on 50 Hz will shift by -1. A 50 Hz unit used on 60 Hz will shift by +1. (Ex. 4% unbalance on 60 Hz, would be 3% unbalance on 50 Hz.)</p>																					
Reset Voltage																							
Overvoltage Trip Point																							
Reset Voltage																							
Voltage Unbalance:		Adjustable from 2 ... 8%																					
Trip Delay:		Adjustable from 2 ... 20 s																					
		Adjustable-Guaranteed range																					
<b>Phase Reversal</b>																							
Response Time -- Phase Reversal		≤100 ms																					
Reset		Automatic																					
<b>Output</b>																							
Type		Electromechanical relay																					
Form		Single pole double throw (SPDT)																					
Rating		10 A resistive @ 240 V AC; 1/4 hp @ 125 V AC; 1/3 hp @ 250 V AC; max. voltage 277 V AC																					
Life		Mechanical -- 1 x 10 <sup>6</sup> ; Electrical -- 1 x 10 <sup>5</sup>																					
<b>Protection</b>																							
Surge		IEEE C62.41-1991 Level B																					
Isolation Voltage		≥ 2500 V RMS input to output																					
Circuitry		Encapsulated																					
<b>Mechanical</b>																							
Mounting		Surface with 2 #8 (M4 x 0.7) screws or 35 mm DIN rail																					
Package		4.33 x 2.95 x 1.97 in. (110 x 75 x 50 mm)																					
Termination		Screw terminals with captive wire clamps for up to #14 AWG (2.5 mm <sup>2</sup> ) wire Touch proof terminal covers are included																					
<b>Environmental</b>																							
Operating/Storage Temperature		-40°C ... +60°C / -40°C ... +85°C																					
Humidity		95% relative, non-condensing																					
Weight		120 & 240 V AC 380 ... 600 V AC																					
		≅ 8.6 oz (244 g) ≅ 16.3 oz (462 g)																					

7

### Mechanical View

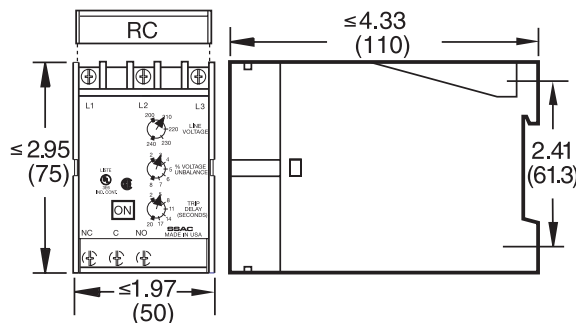

**Mounting Note:**  
Adequate ventilation must be provided. The Ambient Temperature can not exceed 60° C. In some installations at 480 and 600 V AC, there must be up to 0.5 in. (12.2 mm) of space between the DLM and other components.

Inches (Millimeters)  
RC = Removable Terminal Cover