

Delay On Make (Operate) KSD1 Digi-Timer Timing Module



TEN YEAR WARRANTY

Obsolete Specification
Redesigned product is available
See new specifications at:
www.sasac.com/standard/standard.htm

- Fixed
- +/-0.5%
- +/-10%
- 12 ... 230 V
- Encapsulated

Description

The KSD1 Series provides excellent repeat accuracy and extended time delays. This combined with two-terminal, simple series-connection with the load makes the KSD1 Series an ideal choice for timing applications where previously only electromechanical timers were available.

Operation

Upon application of input voltage, the time delay begins. The output is de-energized before and during the time delay. At the end of the time delay, the output is energized and remains energized until input voltage is removed.

Reset: Removing input voltage resets the time delay and output.

■ Approvals:

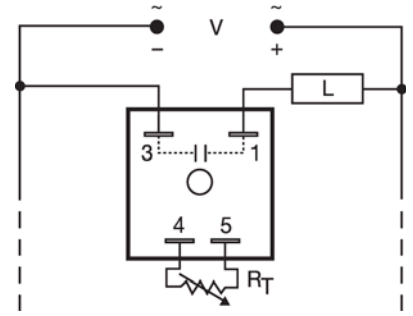

R_T is used when external adjustment is ordered. Load may be connected to terminal 3 or 1.

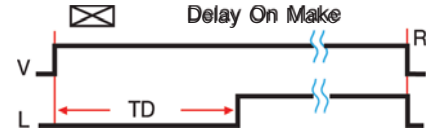

V = Voltage L = Load R = Reset
TD = Time Delay — = Undefined time

Ordering Table

KSD1 Series	X Input Voltage	X Adjustment	X Time Delay*
	-1 - 12 V DC	-1 - Fixed	-0 - 0.1 ... 10 s
	-2 - 24 V AC	-2 - External Adjust	-1 - 1 ... 100 s
	-3 - 24 V DC		-2 - 10 ... 1000 s
	-4 - 120 V AC		-3 - 0.1 ... 10 m
	-6 - 230 V AC		-4 - 1 ... 100 m
			-5 - 5 ... 500 m

*If Fixed Delay is selected, insert delay [0.1 ... 1000] followed by (S) secs. or [0.1 ... 500] (M) mins.

Example P/N: **KSD1421** Fixed - **KSD1410.5S**

Desired Time Delay*						R_T Megohm
Seconds			Minutes			
0	1	2	3	4	5	
0.1	1	10	0.1	1	5	0.0
1	10	100	1	10	50	0.1
2	20	200	2	20	100	0.2
3	30	300	3	30	150	0.3
4	40	400	4	40	200	0.4
5	50	500	5	50	250	0.5
6	60	600	6	60	300	0.6
7	70	700	7	70	350	0.7
8	80	800	8	80	400	0.8
9	90	900	9	90	450	0.9
10	100	1000	10	100	500	1.0

* When selecting an external R_T add at least 20% for tolerance of unit and the R_T .

Technical Data

Time Delay	
Type	Digital integrated circuitry
Range	0.1 s ... 500 m in 6 adjustable ranges or fixed
Repeat Accuracy	+/-0.5% or 16 ms, whichever is greater
Tolerance (Factory Calibration)	≤ +/-10%
Recycle Time	≤ 200 ms
Time Delay vs. Temperature & Voltage	≤ +/-10%
Input	
Voltage	24, 120, or 230 V AC; 12 or 24 V DC
Tolerance	+/-20%
Line Frequency	50 ... 60 Hz
Output	
Type	Solid state
Form	Normally Open, open during timing
Maximum Load Current	1 A steady state, 10 A inrush at 60°C
Minimum Holding Current	≤ 40 mA
Voltage Drop	≅ 2.5 V at 1 A
Protection	
Circuitry	Encapsulated
Dielectric Breakdown	≥ 2000 V RMS terminals to mounting surface
Insulation Resistance	≥ 100 MΩ
Mechanical	
Mounting	Surface mount with one #10 (M5 x 0.8) screw
Package	2 x 2 x 1.21 in. (50.8 x 50.8 x 30.7 mm)
Termination	0.25 in. (6.35 mm) male quick connect terminals
Environmental	
Operating Temperature	-40°C ... +60°C
Storage Temperature	-40°C ... +85°C
Humidity	95% relative, non-condensing
Weight	≅ 2.4 oz (68 g)

Time Delay	VTP P/N
0 - 0.1 ... 10 s	VTP2C
1 - 1 ... 100 s	VTP2G
2 - 10 ... 1000 s	VTP2K
3 - 0.1 ... 10 m	VTP2N
4 - 1 ... 100 m	VTP2P
5 - 5 ... 500 m	VTP2R

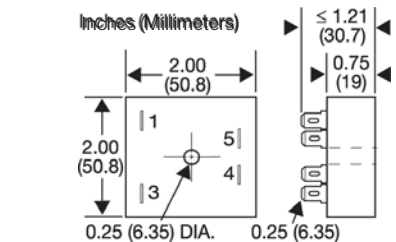

Accessories

- Mounting bracket
P/N: P1023-6
- External adjust potentiometer
P/Ns:
P1004-16 (fig A)
P1004-16-X (fig B)
- Female quick connect
P/N:
P1015-64(AWG 14/16)
- Plug-on adjustment module
P/N:
VTP(X)(X)
- Quick connect to screw adaptor
P/N: P1015-18
- Versa-knob
P/N: P0700-7
- DIN rail adaptor
P/N: P1023-20

DIN rail P/Ns:
C103PM (A)
17322005 (Steel)

See accessory pages at the end of this section.