

Delay On Make - Normally Closed KSD4 Digi-Timer Timing Module

5

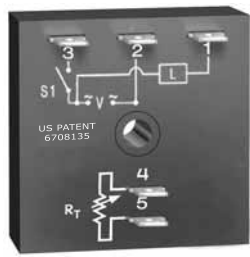

10 YEAR WARRANTY

- Fixed or Adjustable Delays from 0.1 s ... 1000 m
- +/-0.5% Repeat Accuracy
- +/-5% Factory Calibration
- 24, 120, or 230 V AC
- 1 A Solid State Output
- Encapsulated

Approvals:

Accessories

- External adjust potentiometer
P/Ns:
P1004-95 (fig A)
P1004-95-X (fig B)
- Mounting bracket
P/N: **P1023-6**
- Female quick connect
P/N:
P1015-64 (AWG 14/16)
- Quick connect to screw adaptor
P/N: **P1015-18**
- Versa-knob
P/N: **P0700-7**

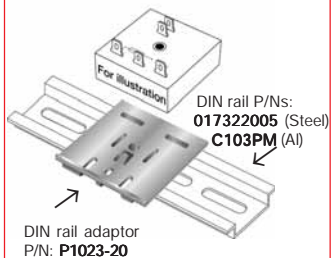

See accessory pages for specifications.

Description

The KSD4 Digi-Timer offers a delay on make function with normally closed solid state output. The load is energized prior to and during the time delay. This series is designed for general purpose commercial and industrial applications where a small, cost effective, reliable solid state timer is required. The factory calibration for fixed time delays is within 5% of the target time delay. The repeat accuracy, under stable conditions, is 0.5% of the selected time delay. This series is designed for input voltages of 24, 120 or 230 V AC. Time delays of 0.1 seconds to 1000 minutes are available in 6 ranges. The output is rated 1 A steady and 10 A inrush. The modules are totally solid state and encapsulated to protect the electronic circuitry.

Operation

Upon application of input voltage, the load energizes immediately. When the initiate switch is closed, the time delay begins. At the end of the time delay, the load de-energizes.

Reset: When the initiate switch is reopened, the load energizes and the time delay is reset. Removing input voltage resets the time delay.

Function

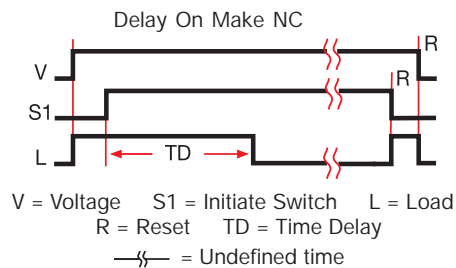

Connection

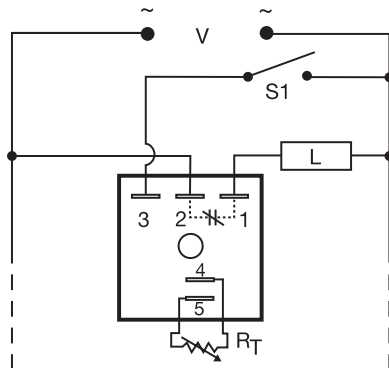

R_T is used when external adjustment is ordered.
Dashed lines are internal connections.
S1 = Initiate Switch

Ordering Table

KSD4 Series	X Input	X Adjustment	X Time Delay*
-2	24 V AC	-1 - Fixed	-0 - 0.1 ... 10 s
-4	120 V AC	-2 - External Adjust	-1 - 1 ... 100 s
-6	230 V AC	-3 - Onboard Adjust	-2 - 10 ... 1000 s
			-3 - 0.1 ... 10 m
			-4 - 1 ... 100 m
			-5 - 10 ... 1000 m

Example P/N: **KSD4421** Fixed – **KSD4410.5S**

*If Fixed Delay is selected, insert delay [0.1 ... 1000] followed by (S) secs. or (M) mins.

Delay On Make - Normally Closed

KSD4 Digi-Timer

Timing Module

Technical Data

Time Delay	
Range	0.1 s ... 1000 m in 6 adjustable ranges or fixed
Repeat Accuracy	+/-0.5% or 20 ms, whichever is greater
Tolerance (Factory Calibration)	≤ +/- 5%
Reset Time	≤ 150 ms
Time Delay vs. Temperature & Voltage	≤ +/-10%
Input	
Voltage	24, 120, or 230 V AC
Tolerance	+/-20%
Line Frequency	50 ... 60 Hz
Power Consumption	≤ 2 VA
Output	
Type	Solid state
Form	Normally Closed, closed before and during timing
Maximum Load Current	1 A steady state, 10 A inrush at 60°C
OFF State Leakage Current	≅ 5 mA at 230 V AC
Voltage Drop	≅ 2.5 V at 1 A
Protection	
Circuitry	Encapsulated
Dielectric Breakdown	≥ 2000 V RMS terminals to mounting surface
Insulation Resistance	≥ 100 MΩ
Mechanical	
Mounting	Surface mount with one #10 (M5 x 0.8) screw
Package	2 x 2 x 1.21 in. (50.8 x 50.8 x 30.7 mm)
Termination	0.25 in. (6.35 mm) male quick connect terminals
Environmental	
Operating Temperature	-40°C ... +60°C
Storage Temperature	-40°C ... +85°C
Humidity	95% relative, non-condensing
Weight	≅ 2.4 oz (68 g)

5

External Resistance vs Time Delay

In Secs. or Mins.

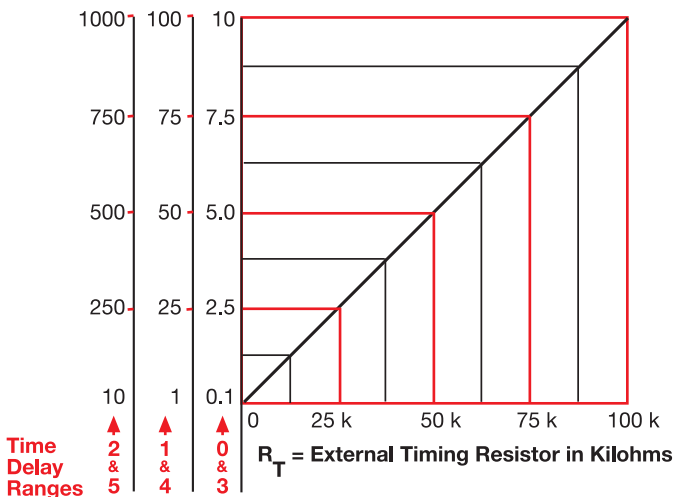

This chart applies to externally adjustable part numbers.

The time delay is adjustable over the time delay range selected by varying the resistance across the R_T terminals; as the resistance increases the time delay increases.

When selecting an external R_T , add the tolerances of the timer and the R_T for the full time range adjustment.

Examples: 1 to 50 S adjustable time delay, select time delay range 1 and a 50 K ohm R_T . For 1 to 100 S use a 100 K ohm R_T .

Mechanical View

Fixed & External Adjust

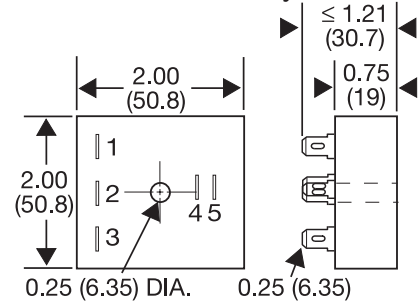

Onboard Adjust

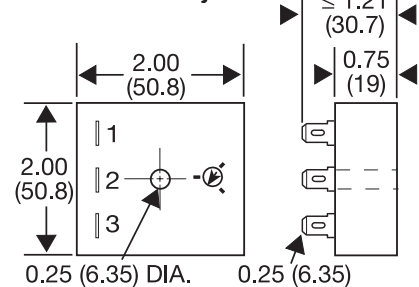

Inches (Millimeters)