

Delay On Break (Release) KSDB Digi-Timer Timing Module



Obsolete Specification
Redesigned product is available
see new specifications at:
www.ssac.com/standard/standard.htm

- Cost Effective
- Accurate
- Fixed Delay
- Fixed Delay
- AC and DC Voltages are Available
- 1 A Steady State Inrush

Description

The KSDB Series' digital circuit provides long or short delays with excellent repeat accuracy. This cost effective timing approach is suitable for industrial and commercial equipment requiring solid state reliability.

Operation

Input voltage must be applied to the input before and during timing. Upon closure of the initiate switch, the output is energized. The time delay begins when the initiate switch is opened. The output remains energized during timing. At the end of the time delay, the output is de-energized. The output will energize if the initiate switch is closed when input voltage is applied.

Reset: Reclosing the initiate switch during timing resets the time delay. Loss of input voltage resets the time delay and output.

- Approvals:

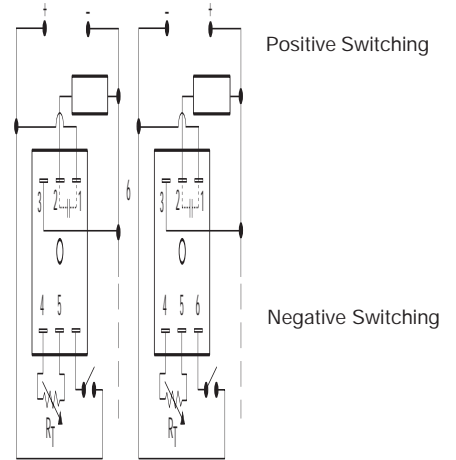

R_T is used when external adjustment is ordered.

Ordering Table

KSDB Series	X Input	X Adjustment	X Time Delay*	X Switching Mode (V DC Only)
-1	12 V DC	-1 - Fixed	-0 - 0.1 ... 10 s	-P - Positive
-2	24 V AC	-2 - External Adjust	-1 - 1 ... 100 s	-N - Negative
-3	24 V DC		-2 - 10 ... 1000 s	
-4	120 V AC		-3 - 0.1 ... 10 m	
-5	120 V DC		-4 - 1 ... 100 m	
-6	230 V AC		-5 - 5 ... 500 m	

* If Fixed Delay is selected, insert delay (0.1 ... 1000) followed by (S) sec. or (0.1 ... 500) (M) min.

Example P/N: **KSDB420** Fixed - **KSDB110.1SP**

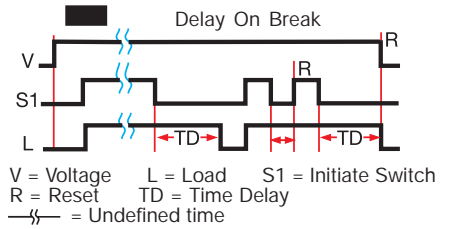

Technical Data

Time Delay	Digital integrated circuitry
Type	Digital integrated circuitry
Range	0.1 s ... 500 m in 6 adjustable ranges or fixed
Repeat Accuracy	+/-0.5 %
Tolerance (Factory Calibration)	≤ +/-10%
Reset Time	≤ 150 ms
Recycle Time	≤ 150 ms
Time Delay vs. Temperature & Voltage	≤ +/-10%
Input	
Voltage	12, 24, or 120 V DC; 24, 120, or 230 V AC
Tolerance	+/-20%
DC Ripple	+/-10%
Line Frequency	50 ... 60 Hz
Output	
Type	Solid state
Form	Normally Open, closed before & during timing
Maximum Load Current	1 A steady state, 10 A inrush at 60°C 0.5 A steady state, 5 A inrush
Voltage Drop	DC ≅ 1.7 V at rated current; AC ≅ 2.5 V at 1 A
DC Operation	Positive or negative switching 120 V DC -- Positive switching only
Protection	
Circuitry	Encapsulated
Dielectric Breakdown	≥ 2000 V RMS terminals to mounting surface
Insulation Resistance	≥ 100 MΩ
Polarity	DC units are reverse polarity protected
Mechanical	
Mounting	Surface mount with one #10 (M5 x 0.8) screw
Termination	0.25 in. (6.35 mm) male quick connect terminals
Operating / Storage Temperature	-40°C ... +60°C / -40°C ... +80°C
Humidity	95% relative, non-condensing
Weight	≅ 2.4 oz (68 g)

Desired Time Delay*	Seconds					R _T Megohm
	0	1	2	3	5	
0.1	1	10	0.1	1	5	0.0
1	10	100	1	10	50	0.5
2	20	200	2	20	100	1.0
3	30	300	3	30	150	1.5
4	40	400	4	40	200	2.0
5	50	500	5	50	250	2.5
6	60	600	6	60	300	3.0
7	70	700	7	70	350	3.5
8	80	800	8	80	400	4.0
9	90	900	9	90	450	4.5
10	100	1000	10	100	500	5.0

* When selecting an external R_T add at least 20% for tolerance of unit and the R_T.

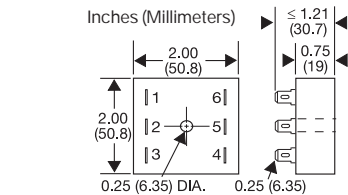

Time Delay	VTP P/N
0 - 0.1 ... 10 s	VTP5C
1 - 1 ... 100 s	VTP5G
2 - 10 ... 1000 s	VTP5K
3 - 0.1 ... 10 m	VTP5N
4 - 1 ... 100 m	VTP5P
5 - 5 ... 500 m	VTP5R

Accessories

- Mounting bracket
P/N: P1023-6
- External adjust potentiometer
P/Ns:
P1004 -13 (fig A)
P1004-13-X (fig B)
- Female quick connect
P/N:
P1015-64 (AWG14/16)
- Plug-on adjustment module
P/N:
VTP(X)(X)
- Quick connect to screw adaptor
P/N: P1015-18
- Versa-knob
P/N: P0700-7
- DIN rail adaptor
P/N: P1023-20
- DIN rail P/Ns:
C103PM (Al)
17322005 (Steel)

See accessory pages at the end of this section.