



SSAC Product Line Conversion Notification March 4, 2005

KSD2 Series Part Numbers

Important Differences Between Product Designs

Specifications	Pre 2005 Design	2005 Generation II Design
Time Delay		
Range	0.1 s ...500 m in 6 adjustable ranges or fixed	0.1 s ... 1000 m in 6 adjustable ranges or fixed
Tolerance (Factory Calibration)	+/-10 %	+/-5%
Operational	Highest time range is 5 to 500 minutes.	Highest time range is 10 to 1000 minutes.
RT Values (for external adjustment)	0-1 MΩ.	0-100 KΩ.(see notes)
Recycle Time	≤ 300 ms	≤ 150 ms
Mechanical		
RT Terminals	Onboard adjustment requires the use of a VTP Plug-on Module.	RT terminals are oriented differently. Can be ordered as onboard adjustable. (see notes)

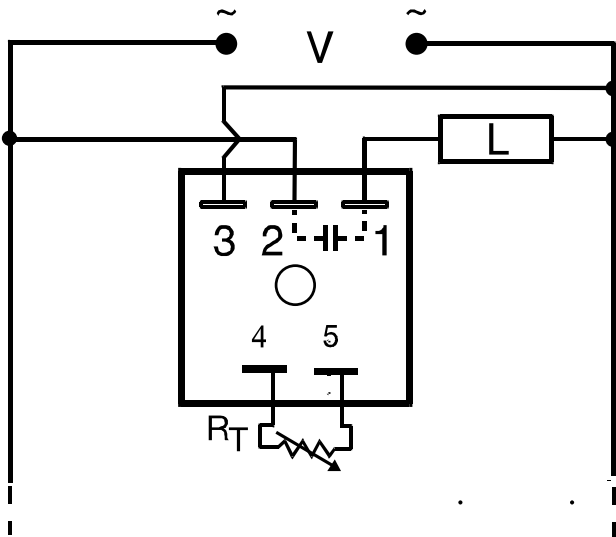

Pre 2005 Design

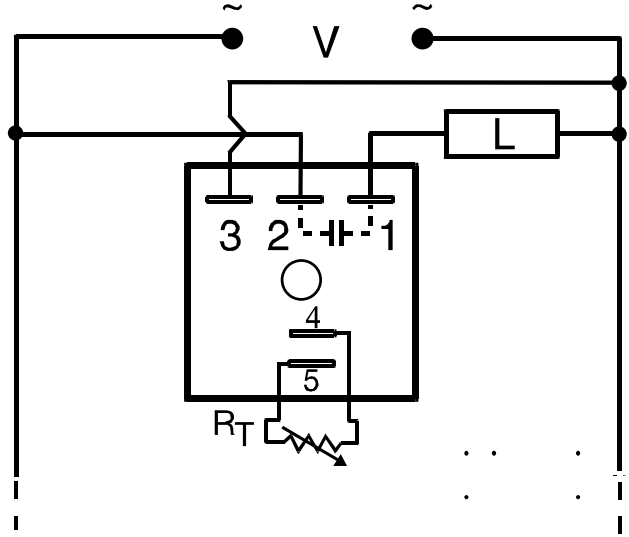

2005 Generation II Design

Legend

V = Input Voltage

L = Timed delayed load

RT = External Adjustment Potentiometer

Dashed lines are internal connections

- Note: 1.) VTP plug-on adjustment modules cannot be used with the 2005 Generation Design. An onboard adjustment option is available for the Generation II design.
 2.) The RT Value cannot exceed 100 k ohms. If the RT exceeds 200k ohms erratic timing may occur. This is normal and not an indication of a defective unit.